



TDA10074 Dual DVB-S2 Demodulator and FEC Decoder

Low-Power DVB-S2 Satellite Demodulator for Dual-Channel STBs

In February 2010, Trident Microsystems acquired the set-top box and television product lines from NXP Semiconductor's home business unit. This product is now a part of Trident's product offering for the set-top box market.

This advanced yet cost-effective DVB-S2 demodulator offers a very small footprint, low power and high performance. Available in a system-level design solution, it gives equipment manufacturers a fast, effective way to deliver a wide range of consumer products.



Applications

- DVB-S2 dual-channel DVR set-top boxes

Key Features

- Ultra-low power
- Internal microcontroller
- Integrated blind scan
- Power-down sleep mode
- DVB-S compatible
- Automatic ± 10 MHz acquisition range
- Integrated SNR and BER monitors
- DiSEqC™ 2.x-compliant
- Symbol rates
 - QPSK (DVBS2): 4.5 - 36 Msps
 - 8PSK (DVBS2): 4.5 - 31 Msps
 - DVBS: 1 - 45 Msps
- Code rates
 - QPSK: 1/2, 3/5, 2/3, 3/4, 4/5, 5/6, 8/9, 9/10
 - 8PSK: 3/5, 2/3, 3/4, 5/6, 8/9, 9/10

- Core voltage: 1.0 V
- I/O voltage: 3.3 V
- 100-pin (eLQFP)

Key Benefits

- Low-power design reduces power regulator cost
- On-board microcontroller shortens software development time
- Sleep mode meets worldwide green initiatives
- DVB-S support addresses any legacy networks
- Internal BER and SNR monitors facilitate production test requirements
- Small footprint (100-pin) conserves valuable PCB board space

The Trident TDA10074 has an automatic acquisition algorithm that searches and acquires the carrier within a ± 10 MHz range during initial acquisition and performs a smart search to reacquire the carrier under fade conditions.

The TDA10074 has an on-chip microcontroller for fast-signal acquisition, Es/No estimation, and system monitoring. In addition, the on-chip microcontroller reduces time to market and conserves valuable software engineering resources because the external driver code is so small.

The TDA10074 uses integrated internal signal-to-noise-ratio (SNR) and bit-error-rate (BER) monitors for channel-performance measurements, so product development and production testing are simpler.

When combined with the CX24132 tuner and the CX24500 HD decoder, the TDA10074 demodulator provides a system-level digital video recorder (DVR) design solution, complete with hardware and software.

TDA10074 Dual DVB-S2 Demodulator and FEC Decoder

TDA10074 DVB-S2 Dual-Channel Demodulator

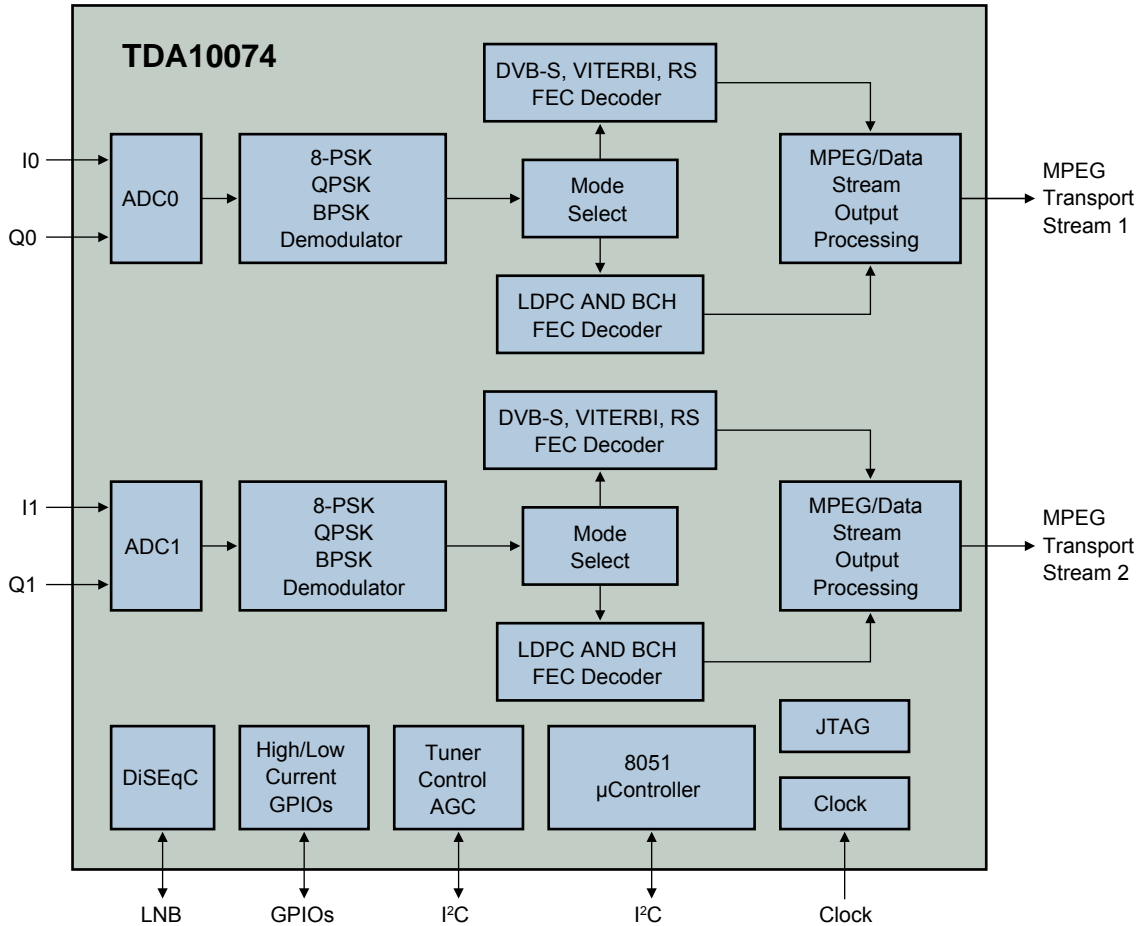

Trident Microsystems, Inc.
1170 Kifer Road
Sunnyvale, CA 94086 USA
408.962.5000 phone
408.991.9307 fax
www.tridentmicro.com